

# A Review Paper Of Artificial Intelligence-Based Power Fault Detection and Power Restoration

**Prof. Kapil Padlak<sup>1</sup>, Manish Nehare<sup>2</sup>, Sheetal Bohrpee<sup>3</sup>**

## **Abstract:**

It has become increasingly challenging to ensure stability and maintain reliability in electrical power systems. Although significant research and technological advancements have been made, a fast and accurate fault detection and classification technique is still needed to ensure security and reduce power outages caused by faults. With a rising population, the demand for electrical power has surged, leading to an increase in power generation units. These units are interconnected through a complex power system network. Malfunctions in the power system can result in significant electrical disruptions, which in turn may lead to substantial economic losses. Therefore, uninterruptible and reliable power transmission is essential to support the country's economic activities. To maintain stability and improve reliability, accurate fault localization is crucial. In real-life scenarios, faulty sections are isolated from healthy parts of the system with the help of relays and circuit breakers, though relay activation may incur a slight delay. Machine learning (ML) models are trained using available data, such as fault voltage and fault current. Currently, research is focused on fault detection and classification using Deep Learning (DL) and ML techniques.

**Keywords:** Artificial Intelligence, Fault Detection, Power Restoration, Smart Grid, Machine Learning, Deep Learning.

## **1. INTRODUCTION:**

Maintaining a high level of service continuity is a primary objective for all power systems, aiming to minimize downtime during exceptional situations. Continuity and reliability are paramount, especially in managing power outages and faults. While weather events, accidents, and equipment failures can disrupt power, it is critical to ensure minimal service interruptions and precise fault localization. For instance, natural events may cause short circuits, commonly referred to as faults. Faults can be symmetrical or asymmetrical, each presenting distinct challenges. In electrical systems with overhead line networks, line-to-ground faults are a primary source of issues, often caused by lightning strikes or trees falling onto lines during windy conditions. When faults occur within the power system, they typically cause significant changes in system parameters. The purpose of power system protection is to minimize false alarms during normal operations and to enhance sensitivity to faults and unusual conditions through the strategic use and design of relays, fuses, or a combination of both. Therefore, it is crucial for protective devices to accurately determine whether an issue indicates an abnormal condition or a transient event that the system can handle and recover from.

**Types of Faults in Power System:****1. Unsymmetrical Faults (Unbalanced)**

These faults involve only one or two phases and cause the system to become unbalanced, meaning the fault currents and phase angles are unequal in the three phases. They are the most common type of fault, accounting for about 95% of power system faults.

**2. Symmetrical Faults (Balanced)**

These faults involve all three phases equally, maintaining the balanced nature of the system (i.e., the phase currents are equal in magnitude and displaced by  $120^\circ$  electrically). They are the least common but the most severe, resulting in the highest fault current.

**2. LITERATURE REVIEWS**

Advanced LSTM ELM-Based Artificial Intelligence Technique for Fault Detection, Classification, and Localization in Modern Electrical Power System Sahoo, Anjan Kumar (January 2025)

In this paper, we propose a rapid and precise technique for fault categorization and identification, based on a hybrid approach combining Deep Learning (DL) and Machine Learning (ML). The IEEE 11-bus, 2-area, 4-machine system was simulated under both faulty and non-faulty conditions. The proposed power system model was tested using both DL-based LSTM methodology and ML-based Extreme Learning Machine (ELM). The performance of both methodologies was compared and analysed.[1].

AI-Driven Fault Detection and Diagnosis in Smart Grids for Enhanced Power System Reliability Dr. Gaurav Goyal, Ismot Tasmay Salsabil, Dr Ashutosh Kumar, Manda Ukey, Dr. Velumani P.S., e-ISSN: 2468-4376 Issue 22, February 2025.

This study explores how AI, using machine learning and deep learning, can improve fault detection and diagnosis in smart grids. It highlights that AI-based systems analyse real-time data from sensors to quickly and accurately identify and classify faults, outperforming traditional methods in speed and precision.[2].

Three Phase Transmission Line Fault Detection & Protection Abhijeet Lad \*1, Ajaykumar Khopkar\*2, Sahil Lad\*3, Vaishnavi Kalaskar\*4, AS Yadav\*5 (IJPREMS) Volume. 03, Issue 05, May 2023

This paper analyzes techniques for fault localization, classification, and detection in three-phase transmission lines and distribution systems. Transmission lines are critical for moving large amounts of power across different regions, but they are sensitive to various atmospheric disasters and faults.[5].

Artificial Intelligence-based Power Fault Detection and Power Restoration B Selvin Sanjay, Saurabh Bansod, Shashank Kumar Singh, Prashant Pal, ISBN: 978-1-6654-8271-4, Issue ICECA 2022.

This research uses Artificial Intelligence (AI), specifically Artificial Neural Networks (ANN), to proactively detect faults in a power system. By analysing data from both the transmission and consumer ends, the ANN model can rapidly identify potential faults. The study's results, visualized in MATLAB, demonstrate the system's ability to predict faults on a simulated transmission line before they cause a widespread outage.[8].

An Intelligent Approach to Locate and Classify Fault in Transmission and Distribution Line Using Computational Intelligence Technique, Mishra D.P. (May 2019)

This paper depicts an approach with an artificial neural network (ANN) for the classification and localization of faults on the power transmission line. A huge number of transmission and distribution lines are used for the transportation of electrical energy in the power system. Moreover, developing a completely reliable system is not possible within the economic and technical limitations. So, there always remains a probability of faults in the transmission lines. When it occurs, it is aimed to locate and classifying the fault to restore the sound condition of the transmission line. For analyzing the transmission line fault, this paper adopts the fault-tolerant neural network-based method as it can process incomplete and noisy data. This

approach can deal with non-linear problems and can carry out the prediction if trained. Feedforward neural networks along with the backpropagation algorithm are used each of the three phases of the transmission line for the fault localization process. The proposed method uses the instantaneous measure of the fault current to return the fault type and the distance from the experimental end. The modelling of the power system and the development of the neural network for this method have been conducted in the MATLAB/Simulink environment. The simulation results illustrated in this paper manifests that the proposed model is promising in performance.[12]

### 3.1 METHODOLOGY

The AI-based fault detection and restoration process includes the following stages:

1. Data Acquisition: Sensors capture voltage and current values.
2. Preprocessing: Removes noise and normalizes input signals.
3. Feature Extraction: Key indicators such as RMS current, voltage dips, and phase angle shifts are extracted.
4. Model Training: Historical fault data is used to train ML/DL models.
5. Fault Detection: Real-time data is compared with trained patterns to identify fault type.
6. Isolation & Restoration: Faulty sections are isolated, and the power supply is restored using automated switching.

### 3.2 Block Diagram

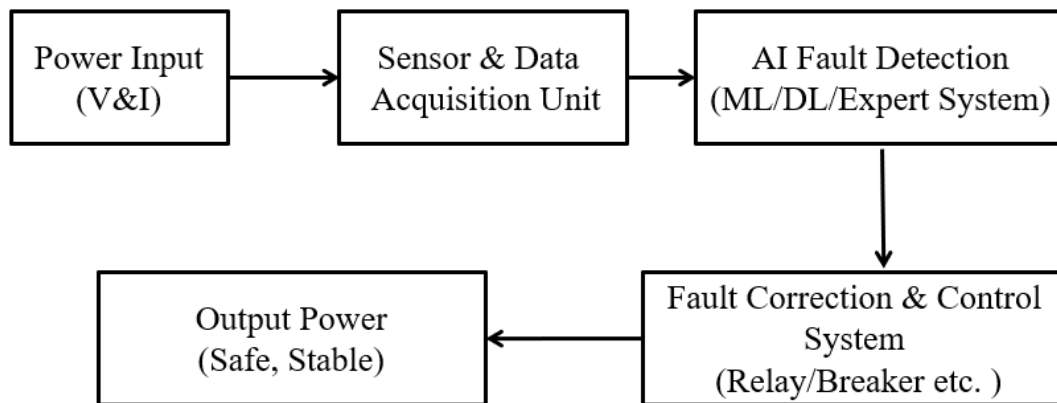

Fig. 3.1 Block Diagram

**3.3 System Components:** The system architecture includes both hardware and software components.

#### 3.3.1 Hardware Components

- I. Current & Voltage Sensors (CT/PT): These sensors continuously measure the voltage and current levels of transmission and distribution lines. They detect sudden variations in electrical quantities during faults, such as short circuits or overloads. The data is then sent to the controller or RTU for processing.
- II. RTU (Remote Terminal Unit): RTUs are field devices used to collect real-time data from sensors and transmit it to the central control system. They convert analog signals from sensors into digital data for AI algorithms. RTUs are often used in substations to gather data from multiple feeders.
- III. IED (Intelligent Electronic Device): IEDs are smart protective devices that can execute control actions such as tripping circuit breakers or isolating faulty sections. They have embedded processors that make local decisions based on AI or pre-programmed logic.
- IV. Microcontroller/Processor: The processing unit where initial data processing and decision-making occur. Microcontrollers such as Arduino, Raspberry Pi, or DSP boards are often used to implement AI-based algorithms and control switching operations.

V. Step-Down Transformer: Since grid voltages are very high, a step-down transformer converts high-voltage signals into a lower, measurable range suitable for sensors and controllers. This ensures that monitoring and data acquisition can be done safely.

VI. Communication Module (Wi-Fi/GSM): These modules enable wireless or wired communication between substations, control centres, and AI servers. Real-time communication is essential for the quick detection, isolation, and restoration of faults

### 3.3.2 Software Components

i. AI Algorithm (ML/DL Models): Used for data analysis, classification, and fault prediction.

ii. Database: Stores historical data for model training.

iii. Visualization Dashboard: Displays grid health and restoration actions.

## 4. ADVANTAGES

1. Improved Accuracy: AI-based fault detection techniques can accurately identify faults, reducing false alarms and misclassification.
2. Faster Restoration: AI-based power restoration techniques can quickly identify the optimal restoration strategy, minimize downtime, and reduce power outage duration.
3. Enhanced Reliability: AI-based techniques can predict potential faults, enabling proactive maintenance and reducing the likelihood of power outages.
4. Increased Efficiency: AI-based techniques can optimize power flow, reducing energy losses and improving overall system efficiency.

## 5. CONCLUSION:

AI-based power fault detection and power restoration techniques have the potential to transform the power industry, enabling efficient, reliable, and secure power supply. However, addressing the challenges and future directions will be crucial to realizing the full potential of AI in power systems. The benefits of AI-based techniques, including improved accuracy, faster restoration, enhanced reliability, and increased efficiency, make them an attractive solution for modernizing power systems. AI-based power fault detection and power restoration techniques have the potential to transform the power industry, enabling efficient, reliable, and secure power supply. However, addressing the challenges and future directions will be crucial to realizing the full potential of AI in power systems. The benefits of AI-based techniques, including improved accuracy, faster restoration, enhanced reliability, and increased efficiency, make them an attractive solution for modernizing power systems.

## REFERENCES:

1. Advanced LSTM ELM-Based Artificial Intelligence Technique for Fault Detection, Classification, and Localization in Modern Electrical Power System Sahoo, Anjan Kumar (January 2025).
2. AI-Driven Fault Detection and Diagnosis in Smart Grids for Enhanced Power System Reliability Dr. Gaurav Goyal, Ismot Tasmay Salsabil, Dr Ashutosh Kumar, Manda Ukey, Dr. Velumani P.S., e-ISSN: 2468-4376 Issue 22, February 2025.
3. Real-Time Fault Detection and Localization in Power Transmission Lines Using Artificial Neural Networks Neha Singh, Sitaram Longani, Pooja Kolhe, e-ISSN NO:0363-8057 VOLUME 11 ISSUE 7 2025
4. Ucar A, Karakose M, Kırımça N. Artificial intelligence for predictive maintenance applications: key components, trustworthiness, and future trends. Applied Sciences. 2024 Jan 20;14(2):898.
5. Three Phase Transmission Line Fault Detection & Protection Abhijeet Lad \*1, Ajaykumar Khopkar\*2, Sahil Lad\*3, Vaishnavi Kalaskar\*4, AS Yadav\*5 (IJPREMS) Volume. 03, Issue 05, May 2023

6. Artificial Intelligence for Fault Detection and Diagnosis in Power Distribution Systems Hitesh Kumawat, Prerna Tundwal, Vikramaditya Dave e-ISSN: 2332-0796 ISSUE 2023
7. Power quality improvement of a proposed grid-connected hybrid system by load flow analysis using static var compensator Mohammad Nurul Absar, Md Fokhrul Islam, Ashik Ahmed e-ISSN:17915 ISSUE 2023
8. Artificial Intelligence-based Power Fault Detection and Power Restoration B Selvin Sanjay, Saurabh Bansod, Shashank Kumar Singh, Prashant Pal, ISBN: 978-1-6654-8271-4, Issue ICECA 2022.
9. Afridi YS, Ahmad K, Hassan L. Artificial intelligence-based prognostic maintenance of renewable energy systems: A review of techniques, challenges, and future research directions. International Journal of Energy Research. 2022 Dec;46(15):21619-42.
10. Lang W, Hu Y, Gong C, Zhang X, Xu H, Deng J. Artificial intelligence-based technique for fault detection and diagnosis of EV motors: A review. IEEE Transactions on Transportation Electrification. 2021 Sep 3;8(1):384-406.
11. Machine learning applications in power system fault diagnosis: Research advancements and perspective Rachna Vaish, U.D. Dwivedi, Saurabh Tewari, S.M. Tripathi, Volume 106 e-j. engappai.2021. 104504 Issue November 2021.
12. An Intelligent Approach to Locate and Classify Fault in Transmission and Distribution Line Using Computational Intelligence Technique Mishra D.P. (May 2019)